



FiberGuard 700

FIBERGUARD PERIMETER INTRUSION DETECTION SYSTEM

The FiberGuard 700

The FiberGuard is a versatile outdoor Perimeter Intrusion Detection System (PIDS) that provides a very reliable and cost effective solution for a variety of perimeters. The FiberGuard can be mounted on a variety of new and existing fences including chain link, welded mesh and palisade.

The major components of the FiberGuard are the fiber optic sensor cable, the FP 770 processor module (electro – optical) and the FM 750 motherboard. The specially designed fiber optic sensor cable is protected by a Kevlar reinforced polyurethane jacket and is suitable for outdoor application in the most extreme environmental conditions.

Configuration

The FiberGuard is attached to the fence in a double loop configuration, beginning at the fiber optic sensor cable output on the FP 770 processor module to the end of the zone and returning to the fiber optic sensor cable input on the FP 770 processor module. Each motherboard FM 750 can accommodate 4 FP 770 processor modules facilitating 4 zones. The FiberGuard can be installed as a “stand alone” PIDS and seamlessly controlled and annunciated by DeTekions’ Open Media Network Interface (OMNI) controller running DeTekions’ or integrated with other sensor systems and controls.



Advantages

- High Probability of Detection (POD)
- Very Low False Alarm Rate (FAR)
- Very Low Nuisance Alarm Rate (NAR)
- The POD & FAR / NAR are optimized by several parameters that can be set individually for each zone including: sensitivity, high & low frequency, low & high threshold, event count & event window and event duration & event mask
- Immune to EMI & RFI
- Immune to lightning strikes
- Can be installed in combustible areas (oil refineries, chemical plants etc')
- Uniform detection along the entire zone
- Can be mounted on various types of fences / barriers
- Can be integrated with a wind anemometer
- Not effected by extreme weather conditions
- Minimal maintenance

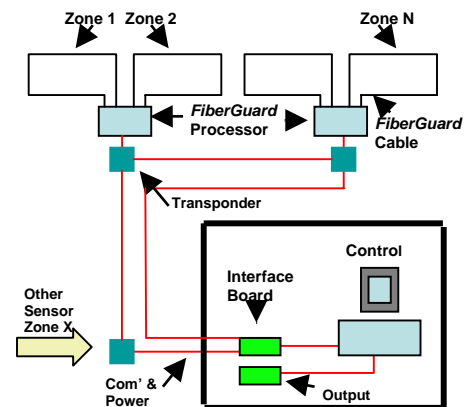

Principle of Operation

A laser diode on the FP 770 processor PCB transmits coded Infra Red (IR) light through the fiber optic sensor cable to a photo diode receiver located on the same FP 770 processor module PCB. The IR appears at the end of the fiber optic sensor cable as a speckle pattern of light and dark patches. Under steady conditions the speckle pattern is relatively stationary. Pressure and vibration applied to the fiber optic sensor cable or to the medium to which it is attached (fence etc') will cause the speckle pattern to change. The change of the speckle pattern is detected by the photo diode receiver and converted into an electronic signal which is electronically processed by the on board digital micro processor running sophisticated proprietary algorithms and if the electronic signal is outside of pre defined parameters an alarm is initiated.

Specifications

General:

Processor Size:	8" x 6" x 1" (20.3cm x 15.2cm x 2.5cm).
Processor Weight:	11 oz. (0.3Kg).
Storage Temperature:	-67°F to 85°F (-55°C to +85°C) ambient.
Operating Temperature:	-22°F to 158°F (-30°C to +70°C) ambient.
Humidity (processor):	20% to 95% relative, condensing.
Max Zone Length	2,500' (762 M')

Electrical & Optics:

Power	Input voltage: 9 – 50 VDC, 0.5 A or 24 – 36 VAC, 0.5 A, Current 28 mA
Laser Type:	Class 1
Fiber Optic Sensor Cable:	Multi Mode (site specific) Mil Spec Tactical Cable, Kevlar Reinforced Polyetherane Jacket
FM 750 Address Selection:	Factory or field set.
Indicators:	One (1) LED for Power One (1) LED each for Alarm & Events. One (1) LED each for Tx Indication & Rx Indication
Outputs:	Five (5) Alarm relays (dry contacts) – For integration with other systems Five (5) Control Open Collector (300 mA) – For use with DeTekion's OMNI controller
Inputs:	Two (2) FiberGuard Zones Two (2) 0-5V dc TTL's.
Maintenance Port:	RS-232, DB-3 pin.
Fiber Optic Bus:	Dual Port (Repeaters).
Wavelength:	820nm.
Cable:	Multimode 50, 62.2 or 100 micron.

Range:

Fiber Optic:	Multimode (6000'), (2Km).
--------------	---------------------------

Jumper selectable:

Four (4) Zone Control.

Connectors:

Communication Ports:	Plug with Screws
Power:	Plug with Screws.
Relay Outputs:	Plug with Screws.
TTL's Inputs:	Plug with Screws
Fiber Optic Sensor Cable:	ST Connectors

Mean Time to Repair:

Less than 30 Min. (PCB replacement).

Mean Time Between Failure:

100,000 Hours.

Warranty:

12 Months from date of approved Installation



DeTekion Security Systems, Inc.

3209 Vestal Parkway East
Vestal, New York 13850
Phone 607-729-7179
Fax 607-729-5149
www.detekion.com

Specifications subject to change without notice